



Model Number

PCV100-F200-B17-V1D

Read head for incident light positioning system

Features

- **Non-contact positioning on Data Matrix code tape**
- **Mechanically rugged: no wearing parts, long operating life, maintenance-free**
- **High resolution and precise positioning, especially for facilities with curves and switch points as well as inclines and declines.**
- **Travel ranges up to 10 km, in X and Y direction**
- **PROFINET interface**
- **Integrated switch**

Diagrams

Coordinates

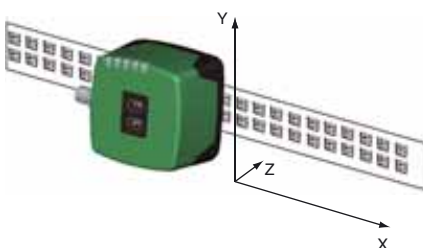

Release date: 2017-09-25 07:44 Date of issue: 2017-09-25 247325_eng.xml

Technical data

General specifications

Passage speed v	≤ 8 m/s
Measuring range	max. 10000 m
Light type	Integrated LED lightning (red)
Read distance	100 mm
Depth of focus	± 20 mm
Reading field	50 mm x 30 mm
Ambient light limit	100000 Lux
Resolution	± 0.1 mm

Nominal ratings

Camera	
Type	CMOS , Global shutter
Processor	
Clock pulse frequency	600 MHz
Speed of computation	4800 MIPS

Functional safety related parameters

MTTF _d	103 a
Mission Time (T _M)	51 a
Diagnostic Coverage (DC)	0 %

Indicators/operating means

LED indicator	7 LEDs (communication, alignment aid, status information)
---------------	---

Electrical specifications

Operating voltage U_B	15 ... 30 V DC , PELV
No-load supply current I_0	max. 400 mA
Power consumption P_0	6 W

Interface

Interface type	100 BASE-TX
Protocol	PROFINET IO Real-Time (RT) Conformance class A
Transfer rate	100 MBit/s

Interface 2

Interface type	USB Service
----------------	-------------

Input

Input type	1 function input
0-level: $-U_B$ or uniwired	
1-level: $+8$ V ... $+U_B$, programmable	
Input impedance	≥ 27 k Ω

Output

Output type	1 to 3 switch outputs , programmable , short-circuit protected
Switching voltage	Operating voltage
Switching current	150 mA each output

Standard conformity

Emitted interference	EN 61000-6-4:2007+A1:2011
Noise immunity	EN 61000-6-2:2005
Shock resistance	EN 60068-2-27:2009
Vibration resistance	EN 60068-2-6:2008

Ambient conditions

Operating temperature	0 ... 60 °C (32 ... 140 °F) , -20 ... 60 °C (-4 ... 140 °F) (noncondensing; prevent icing on the lens!)
Storage temperature	-20 ... 85 °C (-4 ... 185 °F)
Relative humidity	90 % , noncondensing

Mechanical specifications

Connection type	8-pin, M12x1 connector, standard (supply+IO) 4-pin, M12x1 socket, D-coded (LAN) 4-pin, M12x1 socket, D-coded (LAN)
Housing width	70 mm
Housing height	70 mm
Degree of protection	IP67
Material	
Housing	PC/ABS
Mass	approx. 200 g

Approvals and certificates

EAC conformity	TR CU 020/2011
UL approval	cULus Listed, General Purpose, Class 2 Power Source, Type 1 enclosure
CCC approval	CCC approval / marking not required for products rated ≤ 36 V

Dimensions

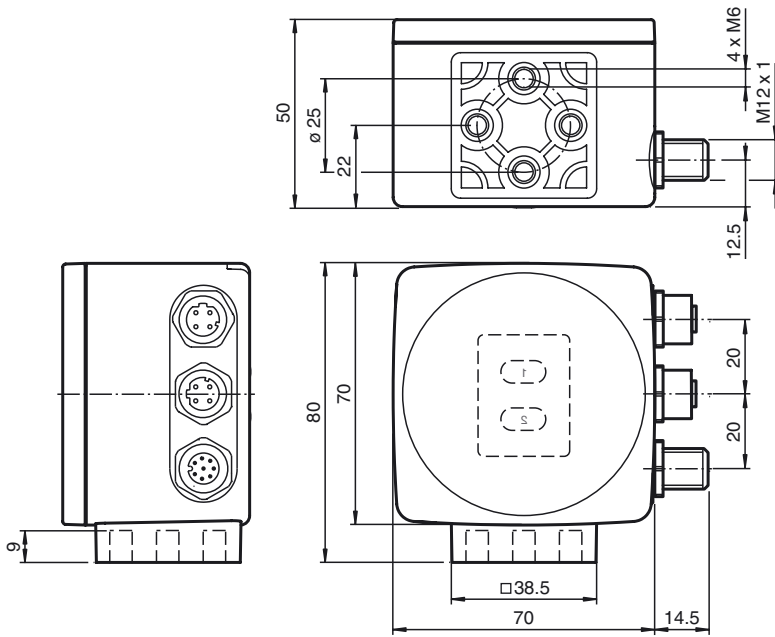

Additional Information

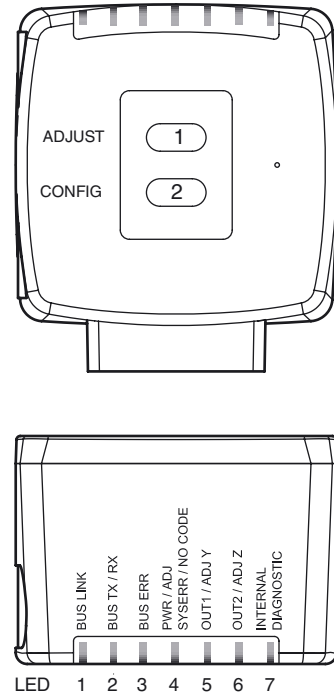

Electrical Connection

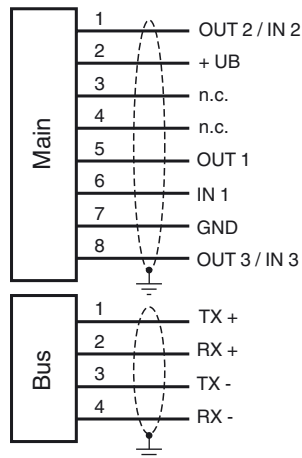

Pinout

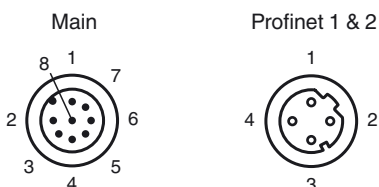

General

The reading head is part of the positioning system in the method for measurement by Pepperl+Fuchs. It consists of a camera module and an integrated illumination unit among other things. The reading head detects position marks, which are put on an adhesive code band in the form of Data Matrix code. The mounting of the code band is as a rule stationary on a firm part of the plant (elevator shaft, overhead conveyor mounting rails...); that of the reading head is parallel on the moving "vehicle" (elevator car, overhead conveyor chassis...).

Accessories

- PCV-SC12**
Grounding clip for PCV system
- PCV-LM25**
Marker head for 25 mm code tape
- V1SD-G-2M-PUR-ABG-V1SD-G**
Ethernet bus cable, M12 to M12, PUR cable 4-pin, CAT5e
- V1SD-G-5M-PUR-ABG-V1SD-G**
Ethernet bus cable, M12 to M12, PUR cable 4-pin, CAT5e
- PCV-AG100**
Alignment guide for PCV100-* read head
- PCV-MB1**
Mounting bracket for PCV* read head
- V19-G-ABG-PG9-FE**
Female connector, M12, 8-pin, shielded, field attachable
- V19-G-ABG-PG9**
Female connector, M12, 8-pin, shielded, field attachable
- PCV-SC12A**
Grounding clip for PCV system
- V19-G-2M-PUR-ABG**
Female cordset, M12, 8-pin, shielded, PUR cable
- V19-G-10M-PUR-ABG**
Female cordset, M12, 8-pin, shielded, PUR cable
- V19-G-5M-PUR-ABG**
Female cordset, M12, 8-pin, shielded, PUR cable
- V1SD-G-5M-PUR-ABG-V45-G**

Release date: 2017-09-25 07:44 Date of issue: 2017-09-25 247325_eng.xml

Mounting and commissioning

Mount the reading head such that its optical surface captures the optimal read distance to the code band (see Technical Data). The stability of the mounting and the guidance of the vehicle must be provided such that the depth of field of the reading head is not closed during operation. All reading heads can be optimally customized by parameterization for specific requirements.

Displays and Controls

The reading head allows visual function check and fast diagnosis with 7 indicator LEDs. The reading head has 2 buttons on the reverse of the device to activate the alignment aid and parameterization mode.

LEDs

LED	Color	Label	Meaning
1	green	BUS LINK	PROFINET communication active
2	yellow	BUS TX / RX	Data transfer
3	red	BUS ERR	PROFINET communication Error
4	red / green	PWR / ADJ SYSERR / NO CODE	Code recognized / not recognized, Error
5	yellow	OUT1/ADJ Y	Output 1, Alignment aid Y
6	yellow	OUT2/ADJ Z	Output 2, Alignment aid Z
7	red/green/yellow	INTERNAL DIAGNOSTIC	Internal diagnostics

Alignment aid for the Y and Z coordinates

The activation of the alignment aid is only possible within 10 minutes of switching on the reading head. The switchover from normal operation to "alignment aid operating mode is via button 1 on the reverse of the reading head.

- Press the button 1 for longer than 2 s. LED4 flashes green for a recognized code band. LED4 flashes red for an unrecognized code band.
- **Z coordinate:** If the distance of the camera to the code band too small, the yellow LED6 lights up. If the distance of the camera to the code band too large, the yellow LED6 lights up. Within the target range, the yellow LED6 flashes at the same time as the green LED4.
- **Y coordinate:** If the optical axis of the camera is too deep in relation to the middle of the code band, the yellow LED5 lights up. If the optical axis is too high, the yellow LED5 extinguishes. Within the target range, the yellow LED5 flashes at the same time as the green LED4.
- A short press on button 1 ends the alignment aid and the reading head changes to normal operation.